

Yüksek kalite **boru** ve **profil** üreticisi

*High quality steel **tubes** and **hollow** sections producer*



YÜCEL boru



YÜCEL grup

YÜCEL grup

 **YÜCEL** boru

 **KROMAN** çelik

 **ÇELSANTAŞ** çelik

 **ÇAYIROVA** boru

 **ÇEMSAT** çelik

 **DEMTRANS** taşımacılık

 **YÜCEL** ihracat ithalat

 **YÜCEL** eko-tarım



Yücel Boru Fabrika - Osmaniye
Yücel Boru Factory - Osmaniye

Türkiye'nin önde gelen çelik boru ve profil üreticisi Yücel Boru ve Profil, 1969 yılında başladığı üretimine bugün Gebze, Osmaniye ve Yeşilköy üretim tesislerinde, ISO 9001, ISO 14001 ve OHSAS TS 18001 standartlarında devam etmektedir.

Yücel Boru ve Profil, Turkey's leading steel tubes and hollow sections producer, started production in 1969 and since then has been conducting operations in Gebze, Osmaniye and Yeşilköy facilities which comply with ISO 9001, ISO 14001 and OHSAS TS 18001 standards.

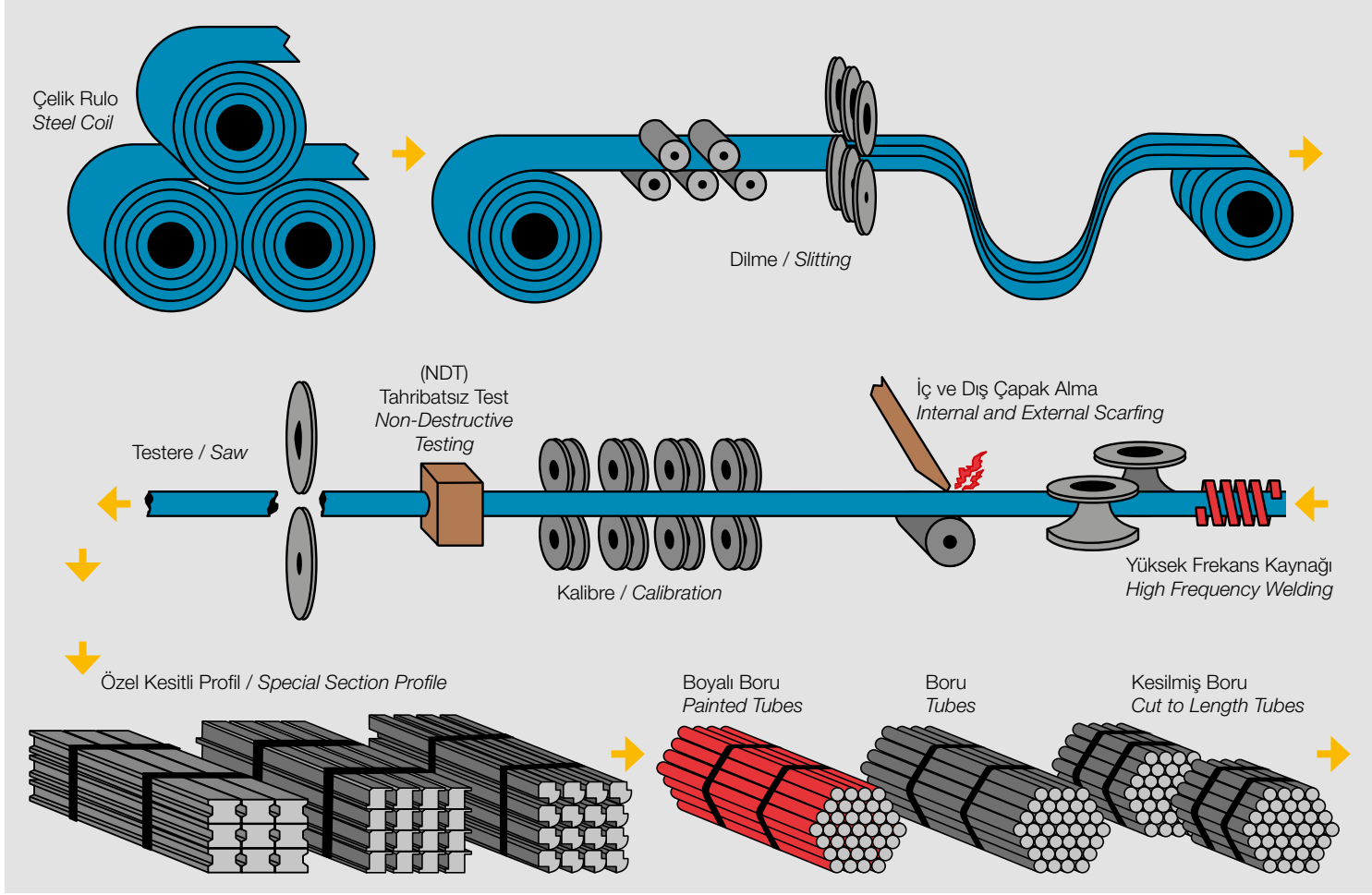

Dilme

Çeşitli kalınlık ve kalitelerdeki çelik rulolar, üretilecek ebada uygun genişliklerde dilimlere ayrılır. Bu sayede çelik rulolar, dilinmiş bant olarak da adlandırılan daha küçük dilimler haline dönüştürülerek boru ve profil üretimine uygun hale gelir.

Slitting

Steel coils of various thicknesses and grades are slitted into the strips based on the width to be produced. In this way, steel coils are transformed into strips, also called slitted coil, making them suitable for tube and hollow section production.



Şekillendirme

Üretime hazır hale getirilmiş, uygun ölçülerdeki dilinmiş bant, şekillendirici makaralar arasından geçirilerek istenilen ölçülerde ürün elde edilir.

Cold Forming

The slit coil of proper dimension prepared for production is passed through the forming rollers to obtain the product with desired final dimensions.

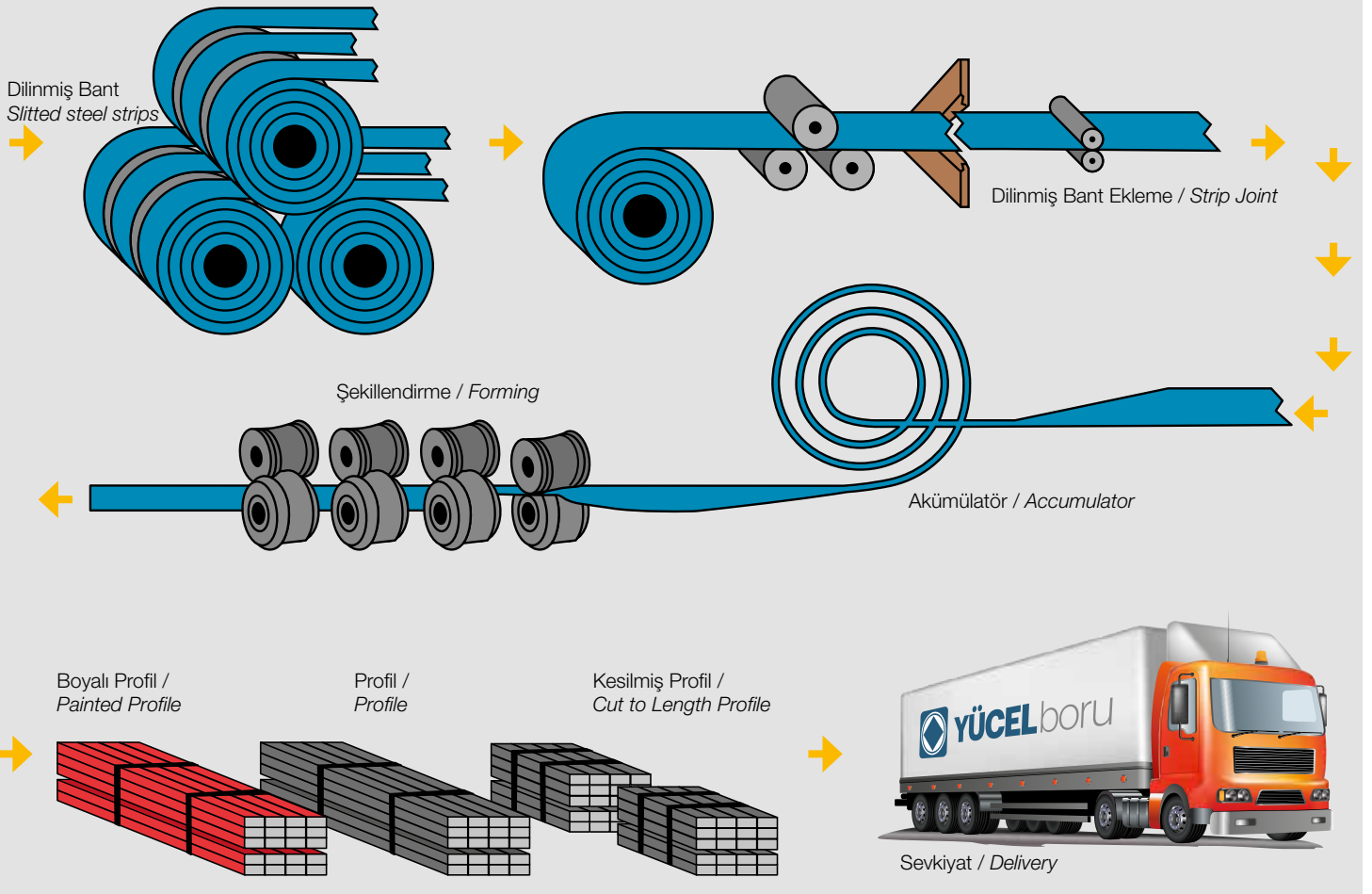

Yüksek Frekans Kaynağı

Yüksek frekanslı akım, manyetik alan yüzeyinden geçtiği zaman kenar kısımlarda ısınmaya sebep olur. V şeklindeki açık kenarların baskı silindirleri yardımıyla kaynaklanması sağlanır.

High Frequency Welding

When the high frequency current passes through the magnetic field surface, it causes heating at the edges. V-shaped open edges are welded through the instrument of pressure rollers.



Boyama

Boru ya da profiller su bazlı boya ile boyanır.

Painting Process

Tubes and hollow sections are painted with water-based paint.



Spektral Analiz Metalik malzemelerin optik emisyon spektrometre cihazı ile kimyasal içeriğini belirlemek amacıyla kullanılan analiz yöntemidir.

Spectral Analysis Spectral Analysis is a method to obtain the chemical content of the material by using optical emission spectrometer device.



Çentik Darbe Testi Çentik darbe testi, ürünün farklı sıcaklıklardaki kırılma enerjisini belirleyerek tokluğu hakkında bilgi verir.

Impact Test (Charpy) The notch impact test determines the fracture energy at different temperatures and provides information about the toughness of the product.



Çekme Testi Çekme testi, ürünün kopma dayanımı, akma dayanımı ve yüzde kopma uzaması gibi mekanik özellikleri hakkında bilgi verir.

Tensile Test Tensile test provides information about mechanical properties of the product, such as tensile strength, yield strength and elongation.



Girdap Akımları Testi (Eddy Current) Ürün üzerinde manyetik alan oluşturularak malzemedeki yüzeysel kusurları tespit etmek amacıyla kullanılan tahribatsız muayene yöntemidir.

Eddy Current Test Eddy current is a non-destructive test method used to determine the surface defects by creating a magnetic field on the product.

Üretim standartları / Production standards

Kare ve Dikdörtgen Profiller:

Square and Rectangular Hollow Sections:

TS EN 10305-5, TS EN 10219-1/2 , TS 5317, ASTM A500, AS/NZS 1163

Borular:

Tubes:

TS EN 10305-3, TS EN 10219-1/2 , TS 8481 EN 39, AS/NZS 1163, TS EN 10255+A1

Ürünlerimiz, TS EN 10219 ve TS EN 10255+A1 için CE belgelidir.

Our products, CE certified for TS EN 10219 and TS EN 10255+A1.

Standartlar İle İlgili Bilgiler:

DIN 2394 (TS 6476) ve DIN 2395 (TS 6475) yürürlükten kaldırıldı. Yerine EN 10305-3 ve EN 10305-5 getirilmiştir.
DIN 2394 (TS 6476) and DIN 2395 (TS 6475) replaced by EN 10305-3 and EN 10305-5

Kullanılan Malzeme Kaliteleri:

Material Qualities:

TS EN 10219: S235JR, S275J0, S275J2, S275MH, S355J0, S355J2, 355K2, S355MH, S420MH, S460MH

TS EN 10305-3 / 5: E155, E195, E235, E275, E355 (+CR1,+A ,+N) / E190, E220, E260, E320, E370, E420 (+CR2) Yüzey durumu *Surface Condition:* S1,S2,S3 ve S4

AS / NZS 1163: C250, C250L0, C350, C350L0, C450, C450L0

ASTM A500: GrA, GrB, GrC, GrD

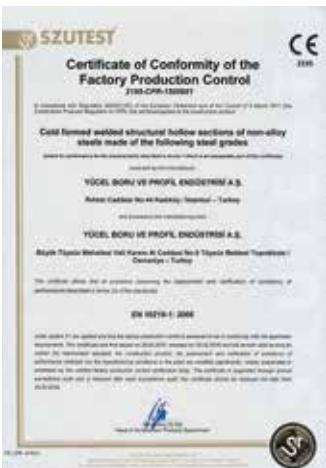
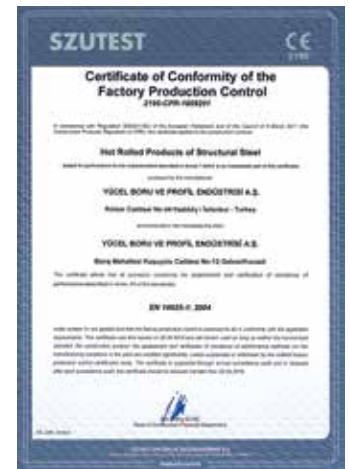





Borular
Steel Tubes

TS EN 10219-2		YAPISAL ÇELİK BORULAR-DİKİŞLİ ALAŞIMSIZ İNCE TANELİ ÇELİKLERDEN SOĞUK ŞEKİLLENDİRİLEREK KAYNAK EDİLMİŞ COLD FORMED WELDED STRUCTURAL HOLLOW SECTIONS OF NON-ALLOY AND FINE GRAIN STEELS									
Dış Çap Outside Diameter, D (mm)	Et Kalınlık / Wall Thickness, T (mm)										
	1,4	1,5	2	2,5	3	4	5	6	6,3	8	
Birim Uzunluk Kütle / Mass Per Unit Length, (kg/m)											
13	0,40	0,43									
16	0,50	0,54									
18	0,57	0,61									
19	0,61	0,65									
21,3	0,69	0,73	0,95	1,16							
26,9	0,88	0,94	1,23	1,50	1,77						
33,7	1,12	1,19	1,56	1,92	2,27						
42,4	1,42	1,51	1,99	2,46	2,91	3,79					
48,3	1,62	1,73	2,28	2,82	3,35	4,37	5,34				
60,3	2,03	2,18	2,88	3,56	4,24	5,55	6,82				
76,1	2,58	2,76	3,65	4,54	5,41	7,11	8,77				
88,9	3,02	3,23	4,29	5,33	6,36	8,38	10,3				
101,6			4,91	6,11	7,29	9,63	11,9	14,1	14,8		
114,3				6,89	8,23	10,9	13,5	16,0	16,8		
139,7					10,1	13,4	16,6	19,8	20,7	26,0	
168,3						12,2	16,2	20,1	24,0	31,6	
219,1							21,2	26,4	31,5	41,6	

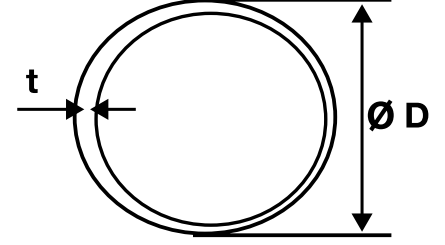

AS/ NZS 1163		SOĞUK ŞEKİLLENDİRİLMİŞ YAPISAL ÇELİK BORULAR COLD-FORMED STRUCTURAL STEEL HOLLOW SECTIONS																	
Dış Çap Outside Diameter D (mm)	Et Kalınlık / Wall Thickness, T (mm)																		
	2,3	2,6	2,9	3,0	3,2	3,5	3,6	4,0	4,5	4,8	4,9	5,0	5,4	5,5	5,9	6,0	6,4	7,1	8,2
Birim Uzunluk Kütle / Mass Per Unit Length, (kg/m)																			
13,5	0,635		0,758																
17,2	0,845		1,02																
21,3		1,20			1,43		1,57												
26,9		1,56			1,87		2,26												
33,7					2,41		2,93	3,24											
42,4					3,09		3,79			4,53									
48,3					3,56		4,37					5,71							
60,3							5,03		6,19			7,31							
76,1	4,19				5,75		6,44		7,95						10,2				
88,9		5,53			6,76		8,38		9,96		10,3		11,3	12,1					
101,6		6,35			7,77		9,63				11,9								
114,3					8,77		9,83		12,2	13,0			14,5			16,0			
139,7				10,1		11,8						16,6	17,9						
165,1				12,0		13,9													
168,3										19,4							25,6	28,2	
219,1										25,4							33,6		42,6

TS EN 10305-3		ÇELİK BORULAR-HASSAS UYGULAMALAR İÇİN-SOĞUK ÖLÇÜLENDİRİLMİŞ DİKİŞLİ BORULAR STEEL TUBES FOR PRECISION APPLICATIONS-WELDED COLD SIZED TUBES															
Dış Çap Outside Diameter D (mm)	Et Kalınlık / Wall Thickness, T (mm)																
	0,6	0,8	0,9	1	1,2	1,5	1,8	2	2,5	3	3,5	4	4,5	5	5,5	6	8
	Birim Uzunluk Kütlesi / Mass Per Unit Length, (kg/m)																
8	0,109	0,142	0,158	0,173	0,201												
10	0,139	0,182	0,202	0,222	0,260	0,314											
12	0,169	0,221	0,246	0,271	0,320	0,388											
15	0,213	0,280	0,313	0,345	0,408	0,499	0,586	0,641									
16	0,228	0,300	0,335	0,370	0,438	0,536	0,630	0,691									
18	0,257	0,339	0,380	0,419	0,497	0,610	0,719	0,789									
19	0,272	0,359	0,402	0,444	0,527	0,647	0,764	0,838									
20	0,287	0,379	0,424	0,469	0,556	0,684	0,808	0,888									
22	0,317	0,418	0,468	0,518	0,616	0,758	0,897	0,986									
25	0,361	0,477	0,535	0,592	0,704	0,869	1,03	1,13	1,39								
28	0,405	0,537	0,601	0,666	0,793	0,980	1,16	1,28	1,57								
30	0,435	0,576	0,646	0,715	0,852	1,05	1,25	1,38	1,70								
32		0,616	0,690	0,765	0,911	1,13	1,34	1,48	1,82	2,15							
35				0,838	1,00	1,24	1,47	1,63	2,00	2,37							
38				0,912	1,09	1,35	1,61	1,78	2,19	2,59	2,98	3,35					
40				0,962	1,15	1,42	1,70	1,87	2,31	2,74	3,15	3,55					
42				1,01	1,21	1,50	1,78	1,97	2,44	2,89	3,32	3,75					
42,4				1,02	1,22	1,51	1,80	1,99	2,46	2,91	3,36	3,79					
44				1,06	1,27	1,57	1,87	2,07	2,56	3,03	3,50	3,95					
45				1,09	1,30	1,61	1,92	2,12	2,62	3,11	3,58	4,04					
48,3				1,17	1,39	1,73	2,06	2,28	2,82	3,35	3,87	4,37	4,86	5,34			
50				1,21	1,44	1,79	2,14	2,37	2,93	3,48	4,01	4,54	5,05	5,55			
51					1,47	1,83	2,18	2,42	2,99	3,55	4,10	4,64					
54						1,94	2,32	2,56	3,17	3,77	4,36	4,93					
57					1,65	2,05	2,45	2,71	3,36	4,00	4,62	5,23	5,83	6,41			
60,3					1,75	2,17	2,60	2,87	3,56	4,24	4,90	5,55	6,19	6,82	7,43		
63,5					1,84	2,29	2,74	3,03	3,76	4,48	5,18	5,87	6,55	7,21	7,87		
70					2,04	2,53	3,03	3,35	4,16	4,96	5,74	6,51	7,27	8,01	8,75		
76,1					2,21	2,76	3,29	3,65	4,53	5,40	6,26	7,10	7,93	8,75	9,56		
88,9						3,23	3,87	4,29	5,33	6,35	7,37	8,37	9,37	10,3			
100							4,36	4,83	6,01	7,18	8,33	9,47	10,6	11,7	12,8	13,9	
101,6							4,43	4,91	6,11	7,29	8,47	9,63	10,8	11,9	13,0	14,1	
108							4,71	5,23	6,50	7,77	9,02	10,3	11,5	12,7	13,9	15,1	
114,3							4,99	5,54	6,89	8,23	9,56	10,9	12,2	13,5	14,8	16,0	
127									7,68	9,17	10,7	12,1	13,6	15,0	16,5	17,9	23,5
139,7									8,46	10,1	11,8	13,4	15,0	16,6	18,2	19,8	26,0
159									9,65	11,5	13,4	15,3	17,1	19,0	20,8	22,6	
168,3										12,2	14,2	16,2	18,2	20,1	22,1	24,0	31,6
219,1										16,0	18,6	21,2	23,8	26,4	29,0	31,5	41,6

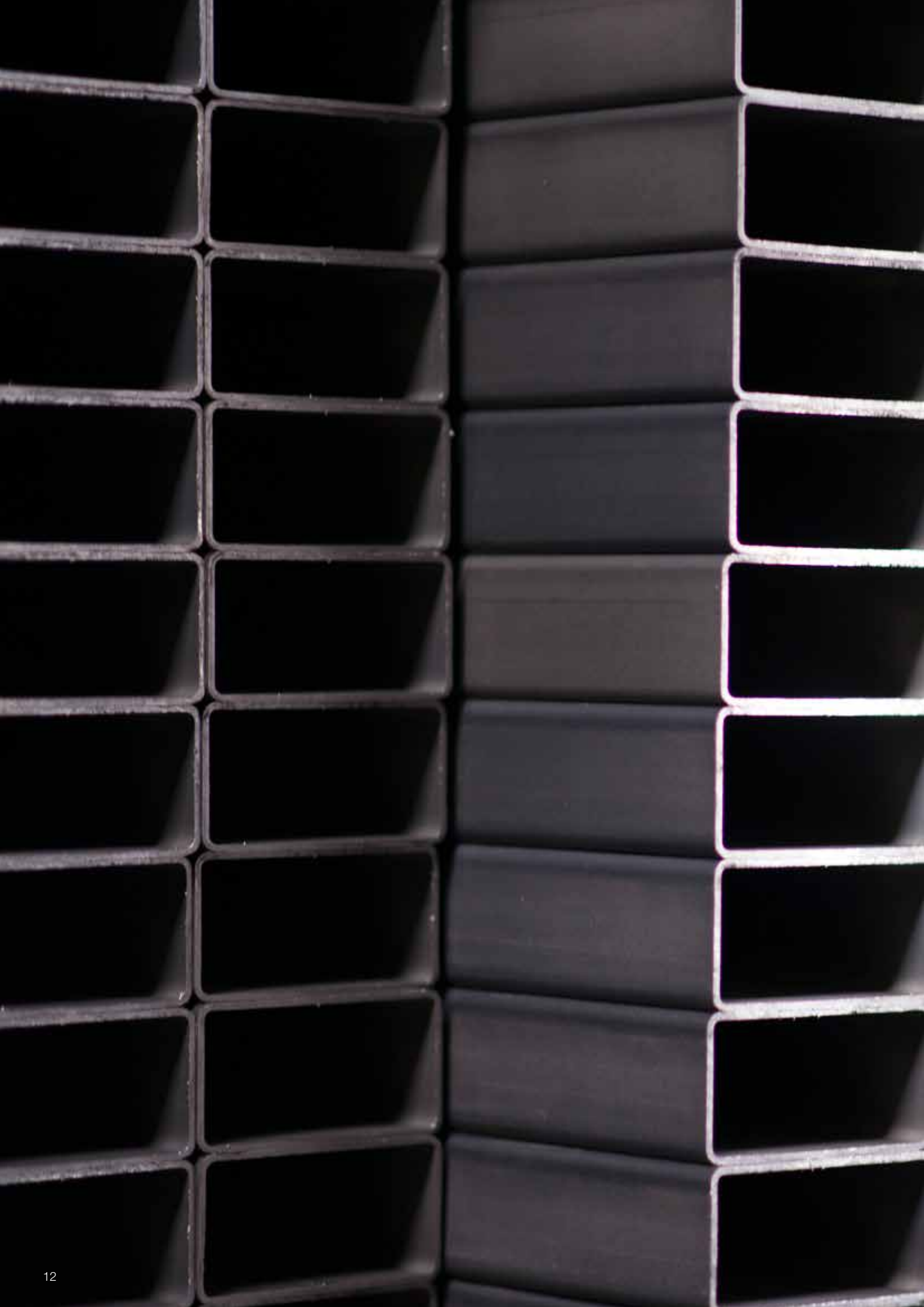



Profiller
Hollow Sections

TS EN 10219-2		YAPISAL ÇELİK PROFİLLER-DİKİŞLİ ALAŞIMSIZ İNCE TANELİ ÇELİKLERDEN SOĞUK ŞEKİLLENDİRİLEREK KAYNAK EDİLMİŞ COLD FORMED WELDED STRUCTURAL HOLLOW SECTIONS OF NON-ALLOY AND FINE GRAIN STEELS																			
Kenar Uzunluğu Side length (mm)		Et Kalınlık / Wall thickness, T (mm)																			
		1,4	1,5	2	2,5	3	4	5	6	6,3	8	10									
B/H	B	Birim Uzunluk Kütle / Mass Per Unit Length, (kg/m)																			
10	10	0,338	0,355																		
15	10	0,448	0,473																		
	15	0,558	0,590																		
18	18	0,690	0,732	0,924																	
20	20	0,778	0,826	1,05	1,25																
25	15	0,778	0,826	1,05	1,25																
	25	0,778	0,826	1,05	1,25																
30	10	0,778	0,826	1,05	1,25																
	20	0,998	1,06	1,36	1,64	1,89															
30	30	0,778	0,826	1,05																	
	20	0,998	1,06	1,36	1,64	1,89															
40	25	1,22	1,30	1,68	2,03	2,36															
	30	1,22	1,30	1,68	2,03	2,36															
	40	1,33	1,41	1,83	2,23	2,60															
45	45	1,44	1,53	1,99	2,42	2,83															
50	20	1,44	1,53	1,99	2,42	2,83															
	25	1,55	1,65	2,15	2,62	3,07	3,88														
	30	1,66	1,77	2,31	2,82	3,30	4,20														
	40	1,88	2,00	2,62	3,21	3,77	4,83														
50	50	2,10	2,24	2,93	3,60	4,25	5,45	6,56													
	20	1,66	1,77	2,31	2,82	3,30	4,20														
	30	1,88	2,00	2,62	3,21	3,77	4,83														
	40	2,10	2,24	2,93	3,60	4,25	5,45	6,56													
60	60	2,54	2,71	3,56	4,39	5,19	6,71	8,13													
	30	2,10	2,24	2,93	3,60	4,25	5,45	6,56													
	40	2,32	2,47	3,25	3,99	4,72	6,08	7,34													
70	50	2,54	2,71	3,56	4,39	5,19	6,71	8,13													
	70	2,98	3,18	4,19	5,17	6,13	7,97	9,70													
	30	2,32	2,47	3,25	3,99	4,72	6,08	7,34													
80	40	2,54	2,71	3,56	4,39	5,19	6,71	8,13													
	60	2,98	3,18	4,19	5,17	6,13	7,97	9,70													
	80			4,82	5,96	7,07	9,22	11,3	13,2												
90	50	2,98	3,18	4,19	5,17	6,13	7,97	9,70													
	90			5,45	6,74	8,01	10,5	12,8	15,1												
100	40	2,98	3,18	4,19	5,17	6,13	7,97	9,70													
	50	3,20	3,42	4,50	5,56	6,60	8,59	10,5													
	60			4,82	5,96	7,07	9,22	11,3	13,2												
	80			5,45	6,74	8,01	10,5	12,8	15,10												
100	100			6,07	7,53	8,96	11,7	14,4	17,0	17,5	21,4										
	30	2,98	3,18	4,19	5,17	6,13	7,97	9,70													
	40	3,42		4,82	5,96	7,07	9,22	11,3	13,2												
	60	3,86		5,45	6,74	8,01	10,5	12,8	15,1												
120	80	4,29		6,07	7,53	8,96	11,7	14,4	17,0												21,4
	100	4,73		6,70	8,31	9,90	13,0	16,0	18,9												23,9
	120			7,33	9,10	10,8	14,2	17,5	20,7	21,4	26,4										
140	60			6,07	7,53	8,96	11,7	14,4	17,0												21,4
	80			6,70	8,31	9,90	13,0	16,0	18,9												23,9
150	50				7,53	8,96	11,7	14,4	17,0												21,4
	100					11,3	14,9	18,3	21,7												27,7
	150					13,7	18,0	22,3	26,4	27,4	33,9										
160	80				9,10	10,8	14,2	17,5	20,7												26,4
175	175					16,0	21,2	26,2	31,1												40,2
200	100					13,7	18,0	22,3	26,4												33,9
	150					16,0	21,2	26,2	31,1												40,2
	200							30,1	35,8												57,0
250	100						21,2	26,2	31,1												40,2
	150							30,1	35,8												57,0
	250								45,2												72,7
300	200								45,2												72,7

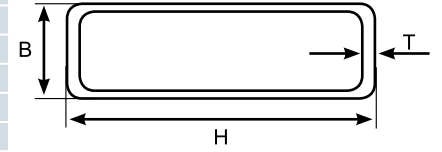
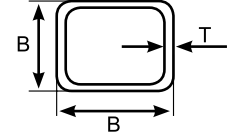

TS EN 10305-5		ÇELİK PROFİLLER-HASSAS UYGULAMALAR İÇİN-SOĞUK ÖLÇÜLENDİRİLMİŞ DİKİŞLİ KARE VE DİKDÖRTGEN KESİTLİ BORULAR STEEL TUBES FOR PRECISION APPLICATIONS-WELDED COLD SIZED SQUARE AND RECTANGULAR TUBES											
Kenar Uzunluğu Side length (mm)		Et Kalınlık / Wall thickness, T (mm)											
		0,7	0,8	0,9	1	1,2	1,25	1,5	2	2,5	3	4	
B/H	B	Birim Uzunluk Kütle / Mass Per Unit Length, (kg/m)											
10	10	0,204	0,230	0,256	0,281	0,329	0,341						
15	15	0,313	0,356	0,397	0,438	0,518	0,537	0,632					
20	10	0,313	0,356	0,397	0,438	0,518	0,537	0,632					
	15	0,368	0,418	0,468	0,516	0,612	0,635	0,750	0,967				
25	20	0,423	0,481	0,538	0,595	0,706	0,733	0,868	1,12	1,36			
	15	0,423	0,481	0,538	0,595	0,706	0,733	0,868	1,12	1,36			
30	25	0,533	0,607	0,680	0,752	0,894	0,930	1,10	1,44	1,76	1,92		
	10	0,423	0,481	0,538	0,595	0,706	0,733	0,868	1,12				
35	15	0,478	0,544	0,609	0,673	0,800	0,831	0,985	1,28				
	20	0,533	0,607	0,680	0,752	0,894	0,930	1,10	1,44	1,76	1,92		
40	30	0,643	0,732	0,821	0,909	1,08	1,13	1,34	1,75	2,15	2,39		
	20				0,830	0,989	1,03	1,22	1,59	1,95			
45	25				0,909	1,08	1,13	1,34	1,75	2,15			
	35				1,07	1,27	1,32	1,57	2,07	2,54	2,86		
50	20	0,643	0,732	0,821	0,909	1,08		1,34	1,75	2,15	2,39		
	25		0,795	0,892	0,987	1,18		1,46	1,91	2,34	2,63		
55	30		0,858	0,962	1,07	1,27		1,57	2,07	2,54	2,86		
	40			1,10	1,22	1,46		1,81	2,38	2,93	3,33	4,25	
60	45					1,65		2,05	2,69	3,33	3,81	4,88	
	20		0,858	0,962	1,07	1,27		1,57	2,07	2,54	2,86		
65	25			1,03	1,14	1,37		1,69	2,22	2,74	3,10	3,94	
	30			1,10	1,22	1,46		1,81	2,38	2,93	3,33	4,25	
70	40					1,65		2,04	2,69	3,33	3,81	4,88	
	50					1,84		2,28	3,01	3,72	4,28	5,51	
75	20			1,10	1,22	1,46		1,81	2,38	2,93	3,33	4,25	
	30					1,65		2,05	2,69	3,33	3,81	4,88	
80	40					1,84		2,28	3,01	3,72	4,28	5,51	
	50					2,02		2,52	3,32	4,11	4,75	6,14	
85	60					2,21		2,75	3,64	4,50	5,22	6,76	
	30					1,84		2,28	3,01	3,72	4,28	5,51	
90	40					2,02		2,52	3,32	4,11	4,75	6,14	
	50					2,21		2,75	3,64	4,50	5,22	6,76	
95	70							3,22	4,26	5,29	6,16	8,02	
	20					1,84		2,28	3,01	3,72	4,28	5,51	
100	30					2,02		2,52	3,32	4,11	4,75	6,14	
	40					2,21		2,75	3,64	4,50	5,22	6,76	
105	50							2,99	3,95	4,90	5,69	7,39	
	60							3,223	4,26	5,29	6,16	8,02	
110	80							4,89	6,07	7,10	9,28		
	50							3,22	4,26	5,29	6,16	8,02	
115	90							5,52	6,86	8,04	10,5		
	40							3,22	4,26	5,29	6,16	8,02	
120	50							3,46	4,58	5,68	6,63	8,65	
	60							4,89	6,07	7,10	9,28		
125	80							5,52	6,86	8,04	10,5		
	100							6,15	7,64	8,99	11,8		
130	40							4,89	6,07	7,10	9,28		
	60							5,52	6,86	8,04	10,5		
135	80							6,15	7,64	8,99	11,8		
	120							7,40	9,21	10,9	14,3		
140	60							6,15	7,64	8,99	11,8		
	80							6,78	8,43	9,93	13,0		
145	50								7,64	8,99	11,8		
	100										11,3	14,9	
150	150										13,7	18,1	
	160									9,21	10,9	14,3	
175	175										16,1	21,2	
200	100										13,7	18,1	
	150										16,1	21,2	
250	100											21,2	

AS / NZS 1163	SOĞUK ŞEKİLLENDİRİLMİŞ YAPISAL KARE KESİTLİ ÇELİK PROFİLLER COLD FORMED STRUCTURAL STEEL HOLLOW SECTIONS							
Ebat Dimensions b x b (mm)	Et Kalınlık / Wall thickness, t (mm)							
	1,60	2,00	2,50	3,00	3,50	4,00	5,00	6,00
Birim Uzunluk Kütlesi / Mass Per Unit Length, (kg/m)								
20	0,873							
25	1,12	1,36	1,64	1,89				
30	1,38	1,68						
35	1,63	1,99	2,42	2,83				
40	1,88	2,31	2,82			4,09		
50	2,38	2,93	3,60	4,25		5,35		
65		3,88	4,78	5,66				
75			5,56	6,60	7,53	8,49	10,3	12,0
89					9,06		12,5	14,6
100				8,96		11,6	14,2	16,7
125						14,8	18,2	21,4
150							22,1	26,2

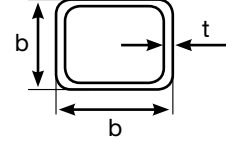

AS / NZS 1163	SOĞUK ŞEKİLLENDİRİLMİŞ YAPISAL DİKDÖRTGEN KESİTLİ ÇELİK PROFİLLER COLD FORMED STRUCTURAL STEEL HOLLOW SECTIONS								
Ebat Dimensions d x b (mm)	Et Kalınlık / Wall thickness, t (mm)								
	1,6	2,0	2,5	3,0	3,5	4,0	5,0	6,0	
d	b	Birim Uzunluk Kütlesi / Mass Per Unit Length, (kg/m)							
50	20	1,63	1,99	2,42	2,83				
50	25	1,75	2,15	2,62	3,07				
65	35		2,93	3,60	4,25				
75	25	2,38	2,93	3,60					
75	50		3,72	4,58	5,42		6,92		
100	50		4,50	5,56	6,60	7,53	8,49	10,3	12,0
125	75				8,96		11,6	14,2	
150	50				8,96		11,6	14,2	
150	100						14,8	18,2	21,4
200	100						17,9	22,1	26,2

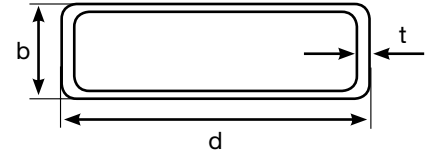

BOYALI ÜRÜN PORTFÖYÜMÜZ / PAINTED PRODUCTS PORTFOLIO			
	EBAT / SIZE (mm)	KALINLIK / THICKNESS (µm)	UZUNLUK / LENGTH (mm)
BORU CIRCULAR HOLLOW SECTION	13 ~ 219,1	1,2 ~ 9	4 ~ 13
PROFİL SQUARE AND RECTANGULAR HOLLOW SECTION	15 X 15 ~ 250 X 250		
	20 X 10 ~ 200 X 150		



**Özel kesitli
Profiller**
*Special Shaped
Sections*

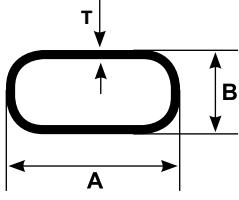

TS EN 10305 OVAL KESİTLİ PROFİLLER / PROFILES WITH OVAL SECTION							
Dış Boyutlar / External Dimensions A x B (mm)	Et Kalınlık / Wall thickness, T (mm)						
	0,7	0,8	0,9	1	1,2	1,5	2
	Ağırlık / Weight, (kg/m)						
21,5 x 15,5	0,32	0,37	0,41	0,45	0,54	0,66	
24 x 14	0,34	0,39	0,43	0,48	0,57	0,70	
30 x 15	0,41	0,47	0,52	0,58	0,69	0,85	1,11
35 x 15	0,47	0,53	0,60	0,66	0,79	0,97	1,27
34 x 16	0,46	0,53	0,59	0,65	0,78	0,96	1,26
35 x 20	0,50	0,57	0,64	0,70	0,84	1,04	1,36
40 x 16	0,53	0,60	0,67	0,75	0,89	1,10	1,44
40 x 20	0,55	0,63	0,71	0,78	0,93	1,16	1,52
42 x 21	0,58	0,66	0,74	0,82	0,98	1,22	1,60
50 x 20		0,76	0,85	0,94	1,12	1,39	1,83
50 x 25		0,79	0,89	0,98	1,18	1,49	1,92
51 x 26		0,81	0,91	1,01	1,20	1,50	1,97
50 x 30			0,93	1,03	1,23	1,53	
50 x 32			0,94	1,05	1,25	1,55	
55 x 25			0,96	1,06	1,27	1,58	2,08
60 x 25					1,39	1,73	2,29

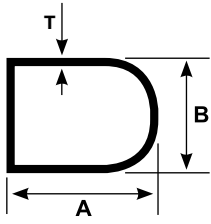

YARI OVAL KESİTLİ PROFİLLER / PROFILES WITH SEMIOVAL SECTION							
Dış Boyutlar / External Dimensions A x B (mm)	Et Kalınlık / Wall thickness, T (mm)						
	0,7	0,8	0,9	1	1,2	1,5	2
	Ağırlık / Weight, (kg/m)						
19 x 25	0,41	0,47	0,52	0,58	0,69	0,85	1,10
34 x 14				0,67	0,80		
40 x 30	0,68	0,78	0,88	0,97	1,16	1,43	1,88

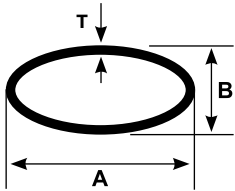

ELİPS KESİTLİ PROFİLLER / PROFILES WITH ELLIPTICAL SECTION							
Dış Boyutlar / External Dimensions A x B (mm)	Et Kalınlık / Wall thickness, T (mm)						
	0,7	0,8	0,9	1	1,2	1,5	2
	Ağırlık / Weight, (kg/m)						
22 x 14	0,30	0,34	0,38	0,42	0,50	0,62	
30 x 15	0,39	0,44	0,49	0,55	0,65	0,80	
40 x 20	0,56	0,59	0,66	0,74	0,88	1,09	1,42
60 x 30					1,41	1,75	2,32

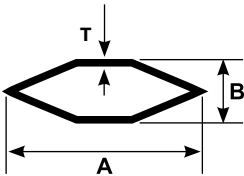

ALTIGEN KESİTLİ PROFİLLER / PROFILES WITH HEXAGONAL SECTION					
Dış Boyutlar / External Dimensions A x B (mm)	Et Kalınlık / Wall thickness, T (mm)				
	0,9	1	1,2	1,5	2
	Ağırlık / Weight, (kg/m)				
56 x 18	0,84	0,93	1,11	1,37	1,80

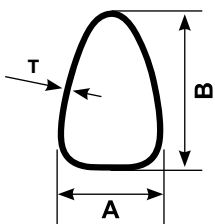

DAMLA KESİTLİ PROFİLLER / PROFILES WITH DROP SHAPES SECTION						
Dış Boyutlar / External Dimensions A x B (mm)	Et Kalınlık / Wall thickness, T (mm)					
	0,8	0,9	1	1,2	1,5	2
	Ağırlık / Weight, (kg/m)					
30 x 45	0,75	0,84	0,94	1,12	1,39	1,83

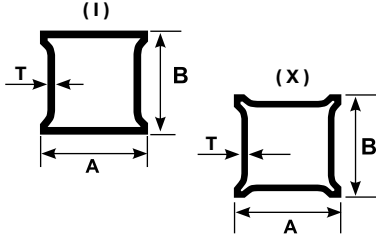

(I / X) KESİTLİ PROFİLLER / PROFILES WITH (I / X) SHAPES SECTION		
Dış Boyutlar / External Dimensions A x B (mm)	Et Kalınlık / Wall thickness, T (mm)	
	0,8	0,9
	Ağırlık / Weight, (kg/m)	
16 x 16 I	0,39	0,44
16 x 16 X	0,40	0,45

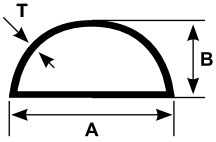

(D) KESİTLİ PROFİLLER / PROFILES WITH (D) SHAPES SECTION		
Dış Boyutlar / External Dimensions A x B (mm)	Et Kalınlık / Wall thickness, T (mm)	
	1,5	2
	Ağırlık / Weight, (kg/m)	
60 x 30	1,75	2,31

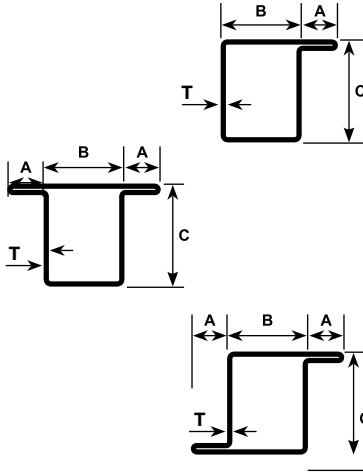

(L / T / Z) KESİTLİ PROFİLLER / PROFILES WITH (L / T / Z) SHAPES SECTION							
Gösterim / Designation	Dış Boyutlar / External Dimensions A x B x C (mm)	Et Kalınlık / Wall thickness, T (mm)					
		0,7	0,8	0,9	1	1,2	1,5
		Ağırlık / Weight, (kg/m)					
28 L	10 x 22 x 28	0,63	0,72	0,8	0,89	1,06	1,35
28 T	10 x 22 x 28		0,84	0,94	1,04	1,25	1,49
28 Z	10 x 22 x 28		0,84	0,94	1,04	1,25	1,49
29 L	13 x 27 x 29		0,81	0,91	1,01	1,20	1,56
38 L	12 x 25 x 38			1,02	1,13	1,35	1,64
38 T	12 x 25 x 38					1,57	1,88
38 Z	12 x 25 x 38					1,57	1,88
38 T	15 x 25 x 38					1,68	2,00

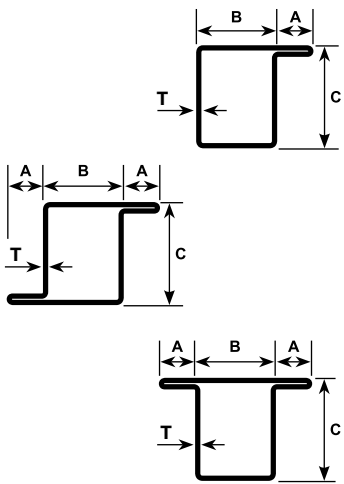

(L / T / Z) KESİTLİ PROFİLLER - PROFILES WITH (L / T / Z) SHAPES SECTION			
Gösterim / Designation	Dış Boyutlar / External Dimensions A x B x C (mm)	Et Kalınlık / Wall thickness, T (mm)	
		1,5	2
		Ağırlık / Weight, (kg/m)	
28 L	12,5 x 25 x 28	1,38	1,82
28 T	12,5 x 25 x 28	1,77	2,35
28 Z	12,5 x 25 x 28	1,77	2,35
33 L	15 x 30 x 33	1,77	2,35
33 T	15 x 30 x 33	2,14	2,84
33 Z	15 x 30 x 33	2,14	2,84

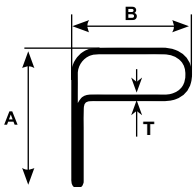

(P) KESİTLİ PROFİLLER / PROFILES WITH (P) SHAPES SECTION	
Dış Boyutlar / External Dimensions A x B (mm)	Et Kalınlık / Wall thickness, T (mm)
	1,2
	Ağırlık / Weight, (kg/m)
35 x 30	1,09

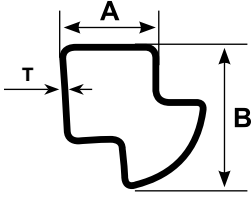

OMEGA KESİTLİ PROFİLLER / PROFILES WITH OMEGA SECTION		
Dış Boyutlar / External Dimensions A x B (mm)	Et Kalınlık / Wall thickness, T (mm)	
	2	3
	Ağırlık / Weight, (kg/m)	
46,5 x 68,5	3,63	5,37

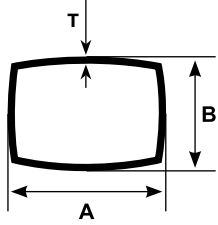

RADÜS KESİTLİ PROFİLLER / PROFILES WITH RADIUS SHAPES SECTION		
Dış Boyutlar / External Dimensions A x B (mm)	Et Kalınlık / Wall thickness, T (mm)	
	1,5	2
	Ağırlık / Weight, (kg/m)	
63,3 x 45,2	2,29	3,02
43,3 x 43,3	1,83	2,41
42,5 x 33,3	1,59	2,10
32,5 x 32,5	1,36	1,78
21,4 x 11,7	0,64	
83,3 x 43,7		3,67

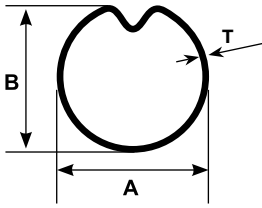

ANTIROTASYON KESİTLİ PROFİLLER / PROFILES WITH ANTIROTATION SECTION		
Dış Boyutlar / External Dimensions A x B (mm)	Et Kalınlık / Wall thickness, T (mm)	
	2	2,5
	Ağırlık / Weight, (kg/m)	
Ø48,3 x Ø46,8	2,43	3,00
Ø60,3 x Ø59,2	3,04	3,76

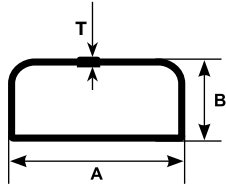

KÜPEŞTE (D) PROFİL / RAILING PROFILES WITH (D) SHAPES			
Dış Boyutlar / External Dimensions A x B (mm)	Et Kalınlık / Wall thickness, T (mm)		
	1,2	1,5	2
	Ağırlık / Weight, (kg/m)		
65 x 30	1,69	2,12	2,81

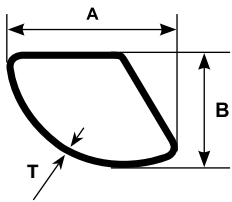

DİLİM PROFİLİ / SLICED SHAPE PROFILE		
Dış Boyutlar / External Dimensions A x B (mm)	Et Kalınlık / Wall thickness, T (mm)	
	1	1,2
	Ağırlık / Weight, (kg/m)	
23 x 16	0,50	0,59

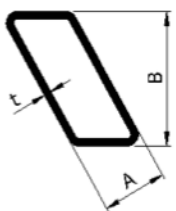

EĞİK PROFİL / OBLIQUE PROFILE		
Dış Boyutlar / External Dimensions A x B (mm)	Et Kalınlık / Wall thickness, T (mm)	
	1,5	2
	Ağırlık / Weight, (kg/m)	
20 x 40	1,34	1,79

TS EN 10219-2
TOLERANSLAR, BOYUTLAR VE KESİT ÖZELLİKLER
TOLERANCES, DIMENSIONS AND SECTIONAL PROPERTIES

Özellik Characteristic	Kütle ve Şekil için Toleranslar / Tolerances on Shape and Mass		
	DAİRE KESİTLİ BORULAR CIRCULAR HOLLOW SECTIONS	KARE ve DİKDÖRTGEN KESİTLİ BORULAR SQUARE AND RECTANGULAR HOLLOW SECTIONS	
	Ø Dış Çap / Outside Diameter, (mm)	Kenar uzunluğu / Side Length, (mm)	
Dış Boyutlar Outside Dimensions, (D, B and H)	± %1 (en az ± 0,5mm ve en çok ±10mm) ± 1 % with a minimum of ± 0,5 mm and a maximum of ±1 0 mm	H, B <100 ± 1 % , min. ±0,5 mm 100 ≤ H, B ≤ 200 ± 0,8 % H,B > 200 ± 0,6 %	
Kalınlık Thickness, (T)	D ≤ 406,4 mm: T ≤ 5 mm ± 10 % T > 5 mm ± 0,5 mm D > 406,4 mm: ± 10 %, max. ± 2mm	T ≤ 5 mm ± 10% T > 5 mm ± 0,5 mm	
Dairesellikten Sapma Out-of-roundness, (O)	Çapın kalınlığa oranı 100'den fazla olamayan borular için ^a % 2 2 % for hollow sections having a diameter to thickness ratio not exceeding 100 ^a	-	
İç Bükeylik / Dış Bükeylik Concavity / Convexity, (x ₁ , x ₂) ^b	-	En çok % 0,8, En az 0,5 mm Max. 0,8 % with a minimum of 0,5 mm	
Kenar Dikliği Squareness of Side, (θ)	-	90 ° ± 1 °	
Dış Köşe Radyüs External Corner Profile (C1, C2 or R ^a)	-	Kalınlık / Thickness, T (mm) Dış köşe (Radius) / External Corner Profile (C1, C2 or Ra) T ≤ 6 6 < T ≤ 10 10 < T 1,6 . T - 2,4 . T 2 . T - 3 . T 2,4 . T - 3,6 . T	
Burulma Twist, (V)	-	2 mm + boyda 0,5 mm/m 2 mm plus 0,5 mm/m length	
Doğrusallık Straightness, (e)	Toplam uzunluğun % 0,20 ve her 1 m'lik boy için 3 mm 0,20 % of total length and 3 mm over any 1 m length	Toplam uzunluğun % 0,15 ve her 1m'lik boy için 3mm 0,15 % of total length and 3mm over any 1m length	
Uzunluk Length, (L)	Boy Tipi ^a / Type of Length	Uzunluk Aralığı veya Uzunluk / Range of Length or Length, L	Tolerans / Tolerance
	Rastgele Uzunluk / Random Length	4000 < L ≤ 16000 (her sipariş için 2000 aralığında) 000 < L ≤ 16 000 (with a range of 2 000 per order item)	10% of sections supplied may be below the minimum for the ordered range but not shorter than 75 % of the minimum range length
	Yaklaşık Uzunluk / Approximate Length	≥ 4000	+50 0 mm
	Tam Uzunluk ^b / Exact Length	< 6000 6000 ≤ L ≤ 10000 > 10000	+5 0 mm +15 0 mm +5 0 mm +1 mm/m
İç Kaynak Dikişi Yüksekliği Internal Weld Bead Height	Kalınlık / Thickness, T	En büyük kaynak dikişi yüksekliği / Maximum weld bead height	
	T ≤ 14.2 ; 3.5 (mm)	T ≤ 14.2 ; 3.5 (mm)	
	T > 14.2 ; 4.8 (mm)	T > 14.2 ; 4.8 (mm)	

TS EN 10305-3 BORU ÇAP TOLERANSLARI
DIAMETER TOLERANCES OF CIRCULAR HOLLOW SECTION

Özellikler / Characteristic	Toleranslar / Tolerances	Kalınlık 6 mm'e kadar / Thickness up to 6 mm			
		Ø Dış Çap / Outside Diameter, (mm)	Tolerans / Tolerances, (mm)		
Et Kalınlık Wall Thickness, (T)	$T \leq 1,5 \text{ mm}$ için ; $\pm 0,15 \text{ mm}$ $T > 1,5 \text{ mm}$ için ; $\pm 0,1.T$ veya $\pm 0,35$ (hangisi küçükse) $T \leq 1,5 \text{ mm}$: $\pm 0,15 \text{ mm}$ $T > 1,5 \text{ mm}$: $\pm 0,1.T$ or $\pm 0,35 \text{ mm}$ (whichever is the smaller)	6	$\pm 0,12$		
		8			
		10			
		12			
		15			
		16			
		18			
		19			
		20			
		22			
İç Çapak Yüksekliği Internal Weld Bead Height	Kaynak alanındaki et kalınlığı belirtilen et kalınlığından küçük olamaz. The thickness of the weld is not allowed to be less than the specified wall thickness.	25	$\pm 0,15$		
		28			
		30			
		32			
		Dairesellikten Sapma Out-of-roundness, (O)	Çap toleranslarına dairesellikten sapma dahildir The diameter tolerances include the out-of-roundness	35	$\pm 0,20$
				38	
				40	
				42	
42.4					
44					
45					
48.3					
Doğrusallık Straightness, (e)	$D > 15 \text{ mm}$ için ; $0,002.L$ $D \leq 15 \text{ mm}$ için; siparişte anlaşma ile belirlenmelidir. (Not 1 ve 2 bakınız) $D > 15 \text{ mm}$; $0,002.L$ $D \leq 15 \text{ mm}$; Shall be agreed at the time of the order (see Note 1 and 2)	50	$\pm 0,25$		
		51			
		55			
		57			
		60			
		63.5			
		70			
		76			
		80			
		89			
Uzunluk Length, (L)	Standart Uzunluk / Standard Length 6000mm, +50/0mm Tam Boy Uzunluk / Exact Lengths ≤ 500 , a $500 < L \leq 2\ 000$, +3/0mm $2\ 000 < L \leq 5\ 000$, +5/0mm $5\ 000 < L \leq 8\ 000$, +10/0mm $> 8\ 000$, a	100	$\pm 0,40$		
		101.6			
		108			
		114			
		120			
		127			
		133			
		139.7			
		159			
		168			
193.7					
			$\pm 0,50$		
			$\pm 0,60$		
			$\pm 0,80$		
			$\pm 1,0$		

Notlar / Notes:

1- Bir metre uzunluk üzerindeki doğruluk tam sapmalar 3 mm'yi geçmemelidir / Deviations from straightness over one metre length shall not exceed 3 mm
 2- 1000 mm altındaki kısa tam uzunlukların doğruluktan sapma sınırı 0,003 L / For exact lengths less than 1 000 mm with an outside diameter $D > 15 \text{ mm}$, the deviation from straightness of any tube length L measured shall not exceed 0,003 L.

a: Tam uzunluk için anlaşma sağlanan bir tek taraflı tolerans belirtilir / by agreement

TS EN 10305-5
PROFİL ÇAP TOLERANSLARI / DIAMETER TOLERANCES OF SQUARE AND RECTANGULAR HOLLOW SECTIONS

Özellikler Characteristic	Toleranslar Tolerances	Kalınlık 4 mm'e kadar / The thickness up to 4 mm				
		B	B/H	Tolerans / Tolerances		
Et Kalınlık Wall Thickness, (T)	T ≤ 1,5 mm için ; ± 0,15 mm T > 1,5 mm için ; ± 0,1.T veya ± 0,35 (hangisi küçükse) T ≤ 1,5 mm: ± 0,15 mm T > 1,5 mm: ± 0,1.T or ± 0,35 mm (whichever is the smaller)	15	15	± 0,20		
		20	10	± 0,20		
			15			
			20			
		25	15	± 0,25		
			25			
Dış Köşe Radyüs External Corner Profile, (C1,C2)	T ≤ 2,5mm; 1,5.T (max) 2,5 mm < T ≤ 4 mm; 2,2.T	30	10	± 0,25		
			15			
			20			
		34	30	± 0,25		
			20			
			25			
İç Kaynak Dikişi Yüksekliği Internal Weld Bead Height	Kaynak alanındaki et kalınlığı belirtilen et kalınlığından küçük olamaz. The thickness of the weld is not allowed to be less than the specified wall thickness.	35	25	± 0,25		
			35			
			20			
		40	25	± 0,30		
			30			
			40			
Kaynak Dikişi Kaçıklığı Nonlinearity of the Weld Seam	Kenar uzunluğunun %10'u kadar veya köşe yarıçapını geçmemeli. Shall not be exceed 10% of the side length or the edge radius	45	45	± 0,30		
			50		20	
					25	
		60		30	± 0,30	
			40			
			50			
Doğrusallık Straightness, (e)	B ve H ≤ 30 ; 0,002 5 L B ve H > 30 ; 0,001 5 L For B and H ≤ 30: 0,002 5 L For B and H > 30: 0,001 5 L	60	20	± 0,35		
			30			
			40			
		70	40	± 0,40		
			70			
			Burulma Twist, (V)		B veya H ≤ 30 mm için ≤ 3 mm ≤ B/10 veya ≤ H/10 için B veya H > 30 mm ≤ 3 mm for B or H ≤ 30 mm B/10 or ≤ H/10 for B or H > 30 mm.	80
30						
40						
Kenar Dikliği Squareness of Side, (θ)	90° ± 1°	90		50		± 0,60
				60		
				80		
Uzunluk Length, (L)	Standart Uzunluk / Standard Length 6000mm, +50/0mm Tam Boy Uzunluk / Exact Lengths ≤ 500, a 500 < L ≤ 2 000, +3/0mm 2 000 < L ≤ 5 000, +5/0mm 5 000 < L ≤ 8 000, +10/0mm > 8 000, a	100	40	± 0,65		
			120		50	
					60	
		İç Bükeylik / Dış Bükeylik Concavity / Convexity, (x ₁ , x ₂) b		B ve H toleranslarına konkavlık ve konvekslik dahildir The concavity and convexity is included in the tolerances of B and H	120	80
			40			
			60			

Not / Note:

a: ≤ 500 mm veya > 8000 mm uzunluklar için toleranslar, siparişte anlaşma ile belirlenmelidir / by agreement

ASTM A500
PROFİL DIŞ BOYUTLAR / EXTERNAL DIMENSIONS PROFILE (B / H)

EBAT / DIMENSION, (mm)	TOLERANS / TOLERANCE, (mm)	
$B / H \leq 65$	\pm	0,5
$65 < B / H \leq 90$	\pm	0,6
$90 < B / H \leq 140$	\pm	0,8
$B / H > 140$	\pm	1%

Çarpılma / Twist (V)

EBAT / DIMENSION (mm)	TOLERANS / TOLERANCE (mm)	
$B / H \leq 40$	1,3	
$40 < B / H \leq 65$	1,6	
$65 < B / H \leq 100$	1,9	
$100 < B / H \leq 150$	2,2	
$150 < B / H \leq 200$	2,5	
$B / H > 200$	2,8	
Kalınlık / Thickness (T)	Et kalınlığının % 10 ' u kadar ($\pm 0,10.T$) Up to 10 % of wall thickness ($\pm 0,10.T$)	
Uzunluk / Length (L)	22 ft (6,5 mt. ve altında olan boylar için) - 6 / + 13 mm	22 ft (6,5 mt. nin üzerinde olan boylar için) - 6 / + 19 mm
Doğrusallık / Straightness	2,08 mm/m. (max)	
Köşe Radyüsü / Radius Of Corners	Et kalınlığının 3 katını geçmemelidir. Shall not exceed 3 times the specified wall thickness	
İç Bükeylik / Dış Bükeylik Concavity / Convexity	$H/B < 1,5$ ise kısa kenar ölçüsü uzun kenar toleransı ile aynı if $H/B < 1,5$ small flat dimension same as the large flat dimension tolerance	
	$1,5 \leq H/B \leq 3$ ise kısa kenar ölçüsü uzun kenar toleransının 1,5 katı if $1,5 \leq H/B \leq 3$ small flat dimension shall be 1,5 times large flat dimension tolerance	
	$H/B > 3$ ise kısa kenar ölçüsü uzun kenar toleransının 2 katı if $H/B > 3$ small flat dimension shall be 2 times large flat dimension tolerance	
Kenar Dikliği / Squareness of Sides	\pm % 2° (max)	
Not / Note	Tüm ölçümler uç kısımlardan 5cm uzaklıktan yapılır All measurements are measured at 5cm from the ends..	

Boru Dış Boyutlar / External Dimensions (D)

$D \leq 48$ mm için / For $D \leq 48$ mm	Çapın $\pm 0,5\%$ 'i kadar Up to $\pm 0,5\%$ of diameter
$D \geq 50$ mm için / For $D \geq 50$ mm	Çapın $\pm 0,75\%$ 'i kadar Up to $\pm 0,75\%$ of diameter

AS / NZS 1163

ŞEKİL ve KÜTLE TOLERANSLARI / TOLERANCES FOR SHAPE AND MASS

Karakteristik Characteristic	Borular Circular Hollow Sections	Kare ve Dikdörtgen Profiller Square and Rectangular Hollow Sections
Ebatlar (do ,d and b) External dimensions	% 1 (en az $\pm 0,5$ mm ve en çok Tolerans ± 10 mm) $\pm 1\%$, with a minimum of ± 0.5 mm and a maximum of ± 10 mm	% 1 (en az $\pm 0,5$ mm) $\pm 1\%$, with minimum of ± 0.5 mm
Kalınlık (t) Thickness	$d_o \leq 406.4$ mm: $\pm 10\%$ $d_o > 406.4$ mm: $\pm 10\%$ max. ± 2 mm	$\pm 0,10\%$
Dairesellikten Sapma (o) Out-of-roundness	Çapın kalınlığa oranı 100'den fazla olmayan borular için % 2 (Not 1'e bakınız) $\pm 2\%$ for hollow sections having a diameter to thickness ratio not exceeding 100 (see Note 1)	—
İç Bükeylik / Dış Bükeylik Concavity / Convexity	—	Max. 0.8% veya 0.5 mm, hangisi büyük ise Max. 0.8% or 0.5 mm, whichever is greater
Kenar Dikliği Squareness of Side	—	$90^\circ \pm 1^\circ$
Dış Köşe Profili (c1, c2 or ro) External Corner Profile	—	50 x 50 eşit veya büyük ise 1.5t - 3.0t Equivalent to 50 x 50 or less 50 x 50 eşit veya büyük ise 1.8t - 3.0t Equivalent to greater than
Çarpıklık (V) Twist	—	2 mm + 0.5 mm/m boyda, length
Doğrusallık Straightness	Toplam uzunluğun % 0,20 0.20% of total length	Toplam uzunluğun % 0,15 0.15% of total length
Uzunluk (L) Length	Rastgele Uzunluk $4\ 000 < L \leq 16\ 000$ (4000 ile 6000 uzunluğunda her sipariş için 2000 aralığında) Random Length $4\ 000 < L \leq 16\ 000$ (4000 to 16 000 with a range of 2000 per order item)	10% of sections supplied may be below the minimum for the ordered range but not less than 75% of the minimum
	Yaklaşık Uzunluk (Belirtilmemiş) All Mill (or 'unspecified') Length	+100 mm -0
	Hassas Uzunluk $\geq 6000 \leq 10\ 000$ Precision Length $\geq 6000 \leq 10\ 000$	+5 mm -0 +15 mm -0 +5 mm + 1 mm/m -0

Notlar / Notes:

1)Çapın kalınlığa oranı 100'den fazla olduğunda, dairesellikten sapma toleransında müşteri ile anlaşma sağlanmalıdır.

Where the diameter to thickness ratio exceeds 100, the tolerance on out-of-roundness becomes the subject of agreement between the manufacturer and purchaser





Türkiye'den dünyaya, kalite ve güven.

Trust and Quality, From Turkey to the World.



4

milyon ton

çelik mamul
*4 million tons of
production*

92 ülkeye

ihracat
*Exports to
92 Countries*



Yücel Boru ve Profil Endüstri A.Ş.

Barış Mahallesi Koşuyolu Caddesi No:12 Gebze 41400 KOCAELİ, TÜRKİYE
Tel: +90262 648 68 00 Fax: +90262 644 46 79 E-mail: info@yucelboru.com.tr
www.yucelboru.com.tr

Yücel Boru İhracat İthalat ve Pazarlama A.Ş.

Rasimpaşa Mahallesi Rıhtım Caddesi No: 44 Kadıköy 41400 İSTANBUL, TÜRKİYE
Tel: +90216 418 10 00 Fax: +90216 338 26 70 E-mail: info@yiip.com.tr, export@yucelboru.com.tr

